

# SPIRIT 70



language



# NEW SPIRIT 70 RANGE

This is the new generation of compact, medium power tractors that also offer high-range technological content and performance.

A range of professional isodiametric tractors, with reversible driving position by standard, made out of 4 different versions each of which is designed and built to fulfil the specific needs of specialised farming:

**AR** – Chassis with central articulation, narrow wheel track and contained turning radii.

**RS** – Chassis with steering wheels, stability and adherence for use also in sloping areas.

**DUALSTEER®** – Chassis with central articulation and steering wheels for unrivalled manoeuvrability in tight spaces.

**MT** – Chassis with steering wheels, configured for haymaking on hills and mountains.

Equipped with a **Stage V 63 hp engine** the new Spirit 70 range was created with an operator-centred project with a completely re-designed driving position to guarantee **maximum comfort** and **total protection** thanks to the new VISTA PRO cab, pressurised and category 4 certified.



# ERGONOMICS AND COMFORT

The reversible driver's seat, with platform suspended on silent block, successfully combines ergonomics and comfort in narrow spaces typical of hyper-specialised tractors.

- Suspended pedals.** Increasing the wheel base by 90 mm made it possible to adopt all suspended pedals leaving space on the platform: therefore the ergonomics are identical for both front drive and reverse.
- Greater seat travel** to increase the living space.
- Reversibility** improved thanks to easier seat tilting with gas spring.
- New joystick armrest** with reduced overall dimensions, longitudinal adjustment and storage compartment.



# NEW CAB

The 4-upright cabin features a conical and compact profile to easily work in tight rows, also on side slopes and in vegetation-rich environments.

The LED working lights, available up a total of 10, light up the working area.



## FEATURES

Monocoque chassis installed on silent block. All-glass doors. Lower hatch closing for ground visibility at the front. Roof hatch with sun-shade. USB car radio with speaker phone and sound diffusers, 2 USB outlets. Interior rear-view mirror, storage compartment and courtesy light. 4 LED working lights (2 front and 2 rear). LED beacon lamp. Fabric seat.

Available in 2 versions:

- VISTA** equipped with ventilation and heating system. Soundproofed and category 2 certified.
- VISTA PRO** equipped with ventilation, heating and air-conditioning system. Soundproofed, **pressurised and category 4 certified** thanks to active carbon filters available optionally. LED working lights on the 4 sides of the cab (10 lights in total).

# MAXIMUM EFFICIENCY

A totally renewed transmission with the same technological content as top-range tractors.

- New Easy Plus™ clutch:** multidisc in oil bath with hydraulic control is electronically controlled by software that filters any poor use of the clutch pedal by the operator, avoiding jerky start-up. Thanks to the Easy Plus™ clutch, progressive engagement is guaranteed, without damage and wear.
- Power Clutch System:** using the button located on the reverser and speed levers, the operator can change the direction of the tractor or change speed without using the clutch pedal, for maximum operating comfort.
- Smart Brake & Go:** this system, which is activated from a button on the dashboard, makes it possible to stop the tractor and restart using only the brake pedal without using the clutch.

These functions, unique among isodiametric tractors, are possible thanks to the **new vehicle control unit of very high automotive standards**, that has allowed us to achieve the most from the electro-hydraulic clutch.

Also the mechanical part of the transmission has been strengthened and upgraded to the **professional objectives that the new Spirit 70 range is required to fulfil:**

- Implementing the **double steering cylinder** into the central articulation (AR version) and for the front axle (RS version).
- Implementing larger planetary reduction units for equipping **20" tyres**.
- Implementing a **forced lubrication circuit** for the bearings and PTO gears.
- A new **braking system** with hydraulic actuation to guarantee suitable stopping spaces in any condition.



Power Clutch System



Smart Brake & Go



# LIFT AND HYDRAULICS

The rear lift has **25% more lifting capacity**.

**Category 2** was also implemented with L-arms adjustable in width and length that increase the possibilities of using increasingly more complex and technological implements, suitable for the new range.

**Over-sized hydraulic system** makes it possible to set the tractor up with up to 5 double-acting control valves with free flow oil return (11 hydraulic outlets in total) and a standard flow rate of about 37 lt/min that switches to a full 48 lt/min in the increased version.

**The new electronically controlled joystick** uses CAN-bus technology and integrates the PTO engagement button and potentiometer to adjust the hydraulic flow rate.



# CLEAN POWER

The engine is **63 hp 4-cylinder Turbo Intercooler** with particulate filter, that BCS Group worked on in collaboration with Kohler for an advanced regeneration strategy guaranteeing maximum performance and reducing machine downtime to a minimum.

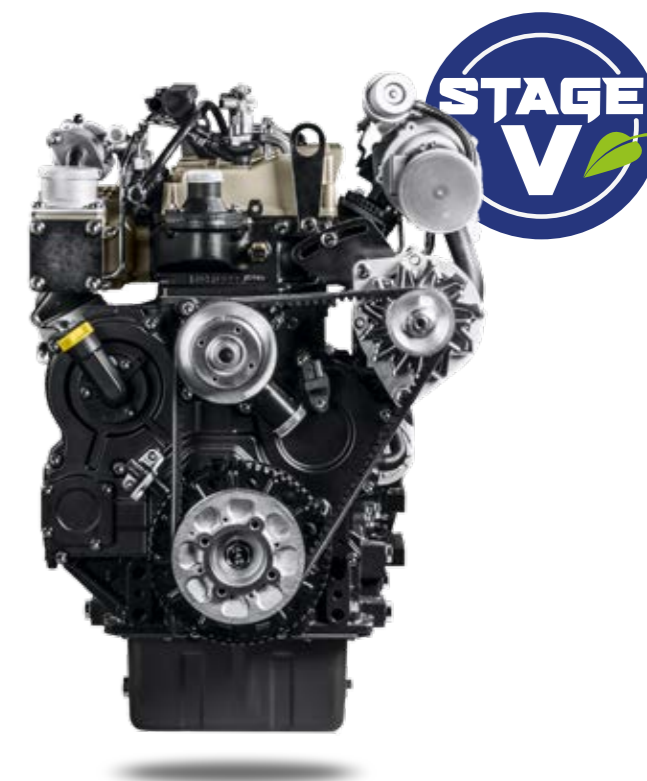

The **rpm is electronically quickly and precisely regulated** with the hand throttle knob on the dashboard. A button allows you to memorize the desired engine speed and, subsequently, to recall / exclude the set engine speed.



# DUALSTEER®

To be agile is a crucial characteristic for all specialised tractors. The market demand is therefore to have **tractors that are ever more agile and manoeuvrable in tight and narrow spaces**, even on a slope, since it is crucial to be able to operate better and achieve high productivity levels.

The **Dualsteer® version**, unique on the market, offers unrivalled manoeuvrability thanks to the double steering system, patented and completely re-designed, that combines and synchronises the central joint of the frame with front wheel steering.

This system makes it possible to achieve a **steering angle of 60°** to exit and enter the next row with a single manoeuvre with evident time saving, increased production and less compaction of the soil.



## WINNING IN EVERY FIELD OF USE

The unrivalled steering radius combined with the stability during manoeuvres also on slopes, make the **Dualsteer® version** the winning solution in numerous fields of use:

- vineyards and orchards with little space for manoeuvres at the end of the field
- greenhouse cultivations
- horticultural-floricultural-nursery sector
- greens maintenance and municipality use

WITH 7.00-18 WHEELS IT ACHIEVES THE NARROWEST CONFIGURATION WITH AN OVERALL WIDTH OF ONLY 1150 MM.

# SPIRIT 70 AR

## Data Sheet

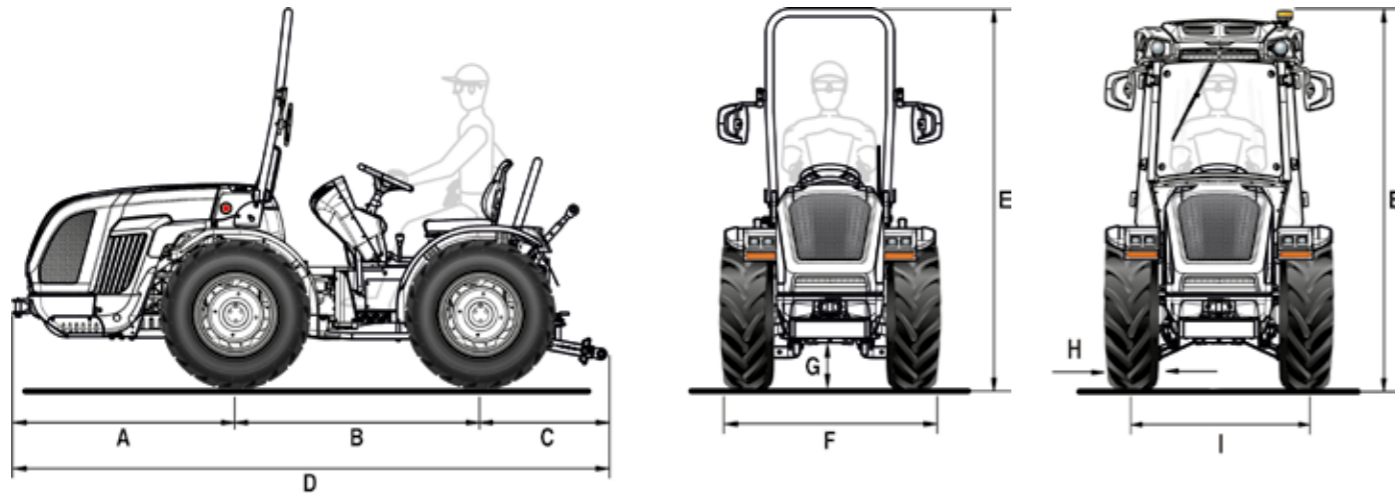

A	B	C	D	E min/max (with roll-bar)	E min/max (with cab)	F min/max	G min/max
1314	1480	735	3529	2215 / 2300	2145 / 2230	1121 / 1525	214 / 299

Dimensions in mm

	250/80-18 with adjustable rim	280/70 R18 with adjustable rim	280/70 R18 Garden with adjustable rim	320/65 R18 with adjustable rim	260/70 R20 with adjustable rim
H	240	282	282	319	258
I	881 / 1107	931 / 1119	931 / 1119	967 / 1119	902 / 1120
F	1121 / 1347	1206 / 1394	1206 / 1394	1286 / 1438	1160 / 1378

	31x15.50-15 XTC with fixed rim	33x15.50-15 XTC with fixed rim	340/65 R18 * with adjustable rim	280/70 R20 * with adjustable rim	280/70 R20 * PneuTrac with adjustable rim
H	368	391	343	282	286
I	1003	1111	1021 / 1119	961 / 1243	1005 / 1205
F	1371	1502	1364 / 1462	1243 / 1525	1291 / 1491

Dimensions in mm - min / max  
H = Tyre width - I = Wheel track - F = Tractor width

\* Oversized planetary reduction units

TECHNICAL FEATURES	SPIRIT 70 AR
<b>ENGINE</b>	Kohler KDI 2504 TCR   Diesel common rail direct injection   Turbo intercooler   4 in-line cylinders 16 valves   2482 cc   Liquid cooling   Stage V
Power	46 kW / 63 hp @2600 rpm   Max torque 205 Nm@1500 rpm
Engine speed management	Electronically regulated with hand throttle knob and button with functions for: memorize/recall/exclude the set engine speed
<b>CHASSIS</b>	Swinging integral chassis (±15°) OS-FRAME with central articulation
<b>DRIVE</b>	Permanent four-wheel drive
<b>TRANSMISSION</b>	24-speed synchronised gearbox: 12 FWD and 12 REV with synchronised reverser
Min/max travel speed (km/h)	0.7 / 35
Transmission clutch	Multidisc in oil bath with electronically-managed and proportional hydraulic control. Power Clutch System button for engaging gears and reverser without using the clutch pedal. PRO-ACT System clutch pedal with Easy Plus™ assisted engagement. Smart Brake & Go function for automatic clutch management only with the brake pedal.
<b>DIFFERENTIAL</b>	Front and rear with simultaneous locking and electro-hydraulic control
<b>AXLES</b>	Front and rear with planetary reduction units - Optional: oversized planetary reduction units
<b>REAR PTO</b>	Independent from the gearbox and synchronised with forwarding speed. Negative safety hydraulic brake to stop the PTO
PTO clutch	Multidisc in oil bath with electro-hydraulic control
PTO rotation speed (rpm)	540/540E
<b>HYDRAULIC SYSTEM</b>	Dual circuit with independent pumps and heat exchanger
Hydraulic pump flow rate of the power steering and electro-hydraulic controls (l/min)	13
Hydraulic pump flow rate of the lift and control valves (l/min)	37 (optional circuit with increased flow rate 48 l/min)
Maximum hydraulic pressure (bar)	180
<b>REAR CONTROL VALVES</b>	Mechanically controlled
Standard	1 double-acting with float and free flow oil return (total 3 hydraulic outlets)
Optional and in addition to the standard ones	With rear up/down lift: up to 7 hydraulic outlets in total - With draft-controlled rear lift: up to 5 hydraulic outlets in total
Joystick (optional)	Proportional electronic control of rear lift and control valves consisting of: 1 continuous flow with adjustable flow rate and free flow oil return, 4 double-acting (replacing the standard ones) and circuit with increased flow rate 48 l/min (total 10 hydraulic outlets). Potentiometer for adjusting joystick sensibility. Remote control for PTO engagement. Storage armrest
<b>REAR LIFT</b>	By two external cylinders. Standard: up/down lift - Optional: position and draft-controlled
Three-point implement hitch	Standard: normal couplings cat. 1 - Optional: quick-couplings cat. 1 (arms not adjustable in length) or quick-couplings cat. 1 and 2, L-shaped, arms adjustable in length and hooks adjustable in width
Third point tie rod	Standard: with manual adjustment - Optional: hydraulically controlled upper link and tie rod link arm (only for lift with L-shaped arms cat. 1 and 2)
Ball joint lifting capacity (kg)	1900
<b>DRIVING POSITION</b>	Reversible with rotating platform suspended on silent blocks. Suspended pedals mounted on the rotating control tower
Steering wheel	Height adjustable
Seat	With gas spring for easy tipping, safety belt and man-on-board sensor. Standard: comfort seat with adjustable spring tension according to the operator's weight - Optional: 'Grammer' or 'Cobo' pneumatic seat
<b>SERVICE BRAKES</b>	Oil bath discs with hydrostatic control, acting on the rear wheels
Parking brake	With handle acting on service brakes
<b>STEERING</b>	Hydrostatic steering acting on the central joint. Flow deviator for steering unit
<b>SAFETY</b>	Front homologated roll-bar with gas spring for easy lowering and lifting
<b>CABIN (optional)</b>	Soundproofed, ROPS and FOPS homologated. Monocoque body with a 4-upright conical structure suspended on silent block. LED beacon lamp, fabric seat, USB car radio with speaker phone and sound diffusers, 2 USB outlets. Available with ventilation and heating system (VISTA model) or with air-conditioning, pressurised and category 4 certified (VISTA PRO model). FULL LED working lights on four sides, optional on VISTA and standard on VISTA PRO. Optional: active carbon filters for category 4
<b>DASHBOARD</b>	Instrument panel with analogue gauges and TFT digital colour display. Warning lights and horn
<b>ELECTRIC SYSTEM</b>	Battery 80 Ah / 12 V - Alternator 95 A
Standard equipment	Vehicle Control Unit, FULL LED street light and indicator system, front LED working lights, rear 7-pin for trailer and 3-pin sockets
<b>TYRES</b>	250/80-18 * 280/70R18 * 280/70R18 Garden * 320/65R18 * 340/65R18 * 260/70R20 * 31x15.50-15 XTC * 33x15.50-15 XTC * 280/70R20 * 280/70R20 PneuTrac
<b>TOW HOOKS</b>	Standard: front and rear CUNA cat. C adjustable in height - Optional: rear tow hook EC approved or EC with Slider frame or CUNA with Slider frame or EC tow bar with Slider frame
<b>RUNNING ORDER WEIGHT</b>	With roll-bar: 1770 kg - With cabin: 1900 kg
<b>ADDITIONAL OPTIONS</b>	Front bumper, beacon lamp, rear adjustable working light, Self Cleaning System™, front weights 110 kg, wheel weights 45 kg each (for 18" wheels) and 50 kg each (for 20" wheels). Silver and bordeaux 'Special Edition' livery

# SPIRIT 70 RS

## Data Sheet

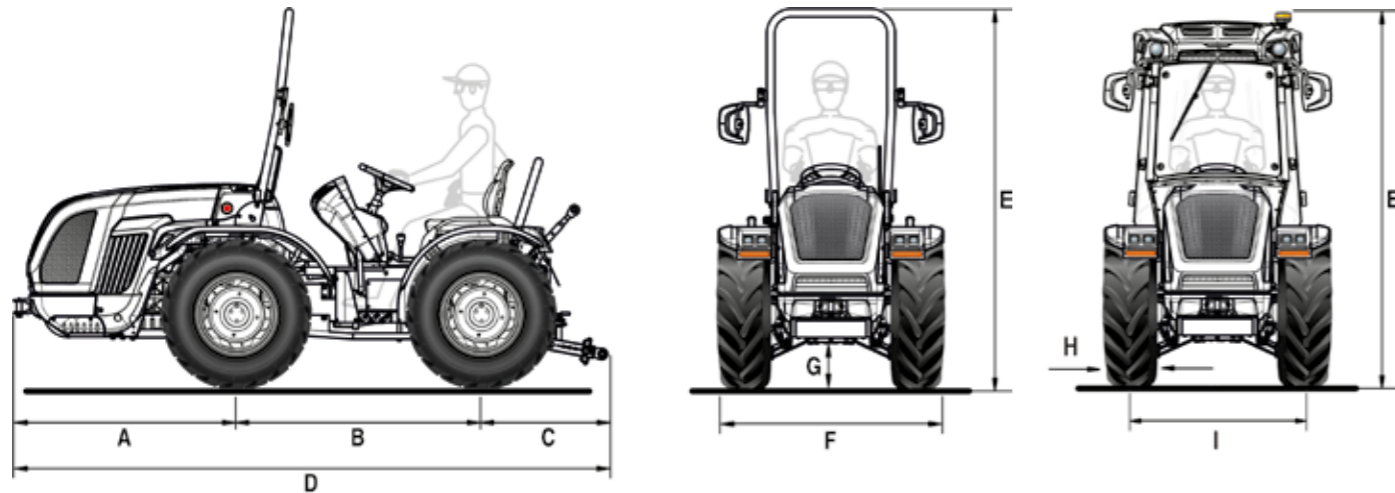

A	B	C	D	E min/max (with roll-bar)	E min/max (with cab)	F min/max	G min/max
1314	1480	735	3529	2215 / 2300	2145 / 2230	1150 / 1764	214 / 299

Dimensions in mm

	7.00-18	250/80-18	280/70 R18	280/70 R18 Garden	280/70 R18	280/70 R18 Garden	320/65 R18	340/65 R18 *	260/70 R20
	with fixed rim	with adjustable rim	with fixed rim	with fixed rim	with adjustable rim	with adjustable rim	with adjustable rim	with adjustable rim	with adjustable rim
H	178	240	265	265	282	282	319	343	258
I	972	996 / 1312	1005	1005	1074 / 1324	1074 / 1324	1074 / 1324	1082 / 1324	1051 / 1325
F	1150	1236 / 1552	1270	1270	1356 / 1606	1356 / 1606	1393 / 1643	1425 / 1667	1309 / 1583

	31x15.50-15 XTC	31x15.50-15 STG	33x15.50-15 XTC	280/70 R20 *	280/70 R20 *	280/70 R20 * PneuTrac	250/85 R20 * (9.50-20)	300/70 R20 *	300/70 R20 * Garden
	with fixed rim	with fixed rim	with fixed rim	with fixed rim	with adjustable rim	with adjustable rim	with adjustable rim	with adjustable rim	with adjustable rim
H	368	394	391	270	282	286	250	286	286
I	1208	1208	1208	1026	1100 / 1448	1062 / 1410	1100 / 1448	1098 / 1478	1098 / 1478
F	1576	1602	1599	1296	1382 / 1730	1348 / 1696	1244 / 1698	1384 / 1764	1384 / 1764

Dimensions in mm - min / max  
H = Tyre width - I = Wheel track - F = Tractor width

\* Oversized planetary reduction units

TECHNICAL FEATURES	SPIRIT 70 RS
<b>ENGINE</b>	Kohler KDI 2504 TCR   Diesel common rail direct injection   Turbo intercooler   4 in-line cylinders 16 valves   2482 cc   Liquid cooling   Stage V
Power	46 kW / 63 hp @2600 rpm   Max torque 205 Nm@1500 rpm
Engine speed management	Electronically regulated with hand throttle knob and button with functions for: memorize/recall/exclude the set engine speed
<b>CHASSIS</b>	Swinging integral chassis (±15°) OS-FRAME with steering wheels
<b>DRIVE</b>	Permanent four-wheel drive
<b>TRANSMISSION</b>	24-speed synchronised gearbox: 12 FWD and 12 REV with synchronised reverser
Min/max travel speed (km/h)	0.7 / 35
Transmission clutch	Multidisc in oil bath with electronically-managed and proportional hydraulic control. Power Clutch System button for engaging gears and reverser without using the clutch pedal. PRO-ACT System clutch pedal with Easy Plus™ assisted engagement. Smart Brake & Go function for automatic clutch management only with the brake pedal.
<b>DIFFERENTIAL</b>	Front and rear with simultaneous locking and electro-hydraulic control
<b>AXLES</b>	Front and rear with planetary reduction units - Optional: oversized planetary reduction units
<b>REAR PTO</b>	Independent from the gearbox and synchronised with forwarding speed. Negative safety hydraulic brake to stop the PTO
PTO clutch	Multidisc in oil bath with electro-hydraulic control
PTO rotation speed (rpm)	540/540E
<b>HYDRAULIC SYSTEM</b>	Dual circuit with independent pumps and heat exchanger
Hydraulic pump flow rate of the power steering and electro-hydraulic controls (l/min)	13
Hydraulic pump flow rate of the lift and control valves (l/min)	37 (optional circuit with increased flow rate 48 l/min)
Maximum hydraulic pressure (bar)	180
<b>REAR CONTROL VALVES</b>	Mechanically controlled
Standard	1 double-acting with float and free flow oil return (total 3 hydraulic outlets)
Optional and in addition to the standard ones	With rear up/down lift: up to 11 hydraulic outlets in total - With draft-controlled rear lift: up to 7 hydraulic outlets in total
Joystick (optional)	Proportional electronic control of rear lift and control valves consisting of: 1 continuous flow with adjustable flow rate and free flow oil return, 4 double-acting (replacing the standard ones) and circuit with increased flow rate 48 l/min (total 10 hydraulic outlets). Potentiometer for adjusting joystick sensibility. Remote control for PTO engagement. Storage armrest
<b>REAR LIFT</b>	By two external cylinders. Standard: up/down lift - Optional: position and draft-controlled
Three-point implement hitch	Standard: normal couplings cat. 1 - Optional: quick-couplings cat. 1 (arms not adjustable in length) or quick-couplings cat. 1 and 2, L-shaped, arms adjustable in length and hooks adjustable in width
Third point tie rod	Standard: with manual adjustment - Optional: hydraulically controlled upper link and tie rod link arm (only for lift with L-shaped arms cat. 1 and 2)
Ball joint lifting capacity (kg)	1900
<b>DRIVING POSITION</b>	Reversible with rotating platform suspended on silent blocks. Suspended pedals mounted on the rotating control tower
Steering wheel	Height adjustable
Seat	With gas spring for easy tipping, safety belt and man-on-board sensor. Standard: comfort seat with adjustable spring tension according to the operator's weight - Optional: 'Grammer' or 'Cobo' pneumatic seat
<b>SERVICE BRAKES</b>	Oil bath discs with hydrostatic control, acting on the rear wheels. Independent manoeuvring brakes acting on the rear wheels
Parking brake	With handle acting on service brakes
<b>STEERING</b>	Hydrostatic steering acting on the front wheels. Flow deviator for steering unit
<b>SAFETY</b>	Front homologated roll-bar with gas spring for easy lowering and lifting
<b>CABIN (optional)</b>	Soundproofed, ROPS and FOPS homologated. Monocoque body with a 4-upright conical structure suspended on silent block. LED beacon lamp, fabric seat, USB car radio with speaker phone and sound diffusers, 2 USB outlets. Available with ventilation and heating system (VISTA model) or with air-conditioning, pressurised and category 4 certified (VISTA PRO model). FULL LED working lights on four sides, optional on VISTA and standard on VISTA PRO. Optional: active carbon filters for category 4
<b>DASHBOARD</b>	Instrument panel with analogue gauges and TFT digital colour display. Warning lights and horn
<b>ELECTRIC SYSTEM</b>	Battery 80 Ah / 12 V - Alternator 95 A
Standard equipment	Vehicle Control Unit, FULL LED street light and indicator system, front LED working lights, rear 7-pin for trailer and 3-pin sockets
<b>TYRES</b>	7.00-18 * 250/80-18 * 280/70R18 * 280/70R18 Garden * 320/65R18 * 340/65R18 * 260/70R20 * 31x15.50-15 XTC or STG * 33x15.50-15 XTC * 300/70R20 * 300/70R20 Garden * 250/85R20 * 280/70R20 * 280/70R20 PneuTrac
<b>TOW HOOKS</b>	Standard: front and rear CUNA cat. C adjustable in height - Optional: rear tow hook EC approved or EC with Slider frame or CUNA with Slider frame or EC tow bar with Slider frame
<b>RUNNING ORDER WEIGHT</b>	With roll-bar: 1830 kg - With cabin: 1960 kg
<b>ADDITIONAL OPTIONS</b>	Front bumper, beacon lamp, rear adjustable working light, Self Cleaning System™, front weights 110 kg, wheel weights 45 kg each (for 18" wheels) and 50 kg each (for 20" wheels), Dual Floating System™ hydraulic suspension. Silver and bordeaux 'Special Edition' livery



# SPIRIT 70 DUALSTEER®

## Data Sheet

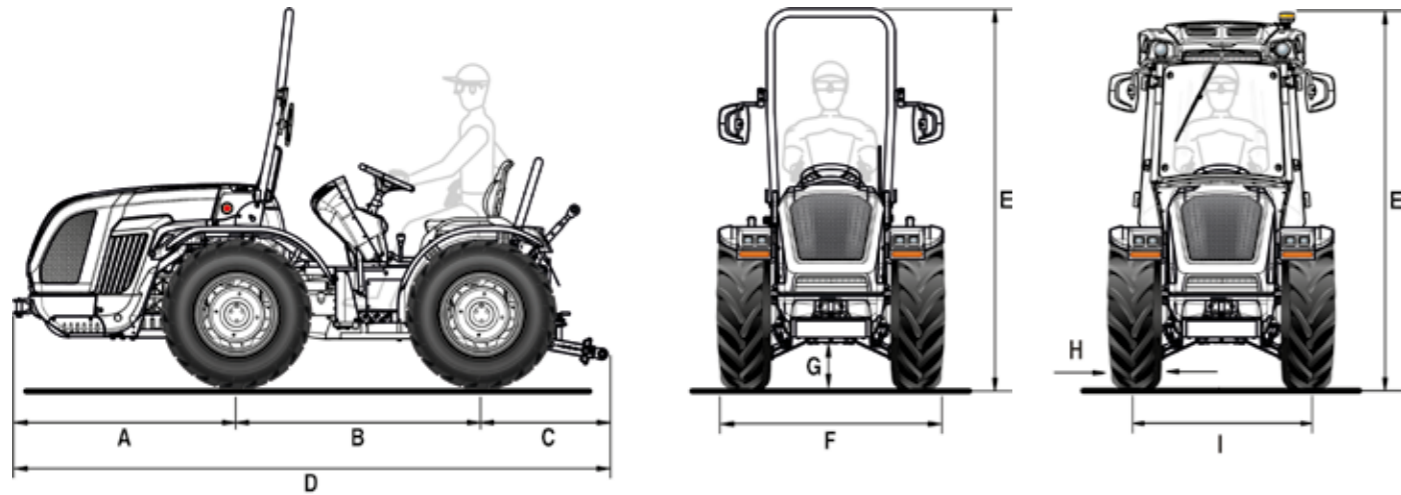

A	B	C	D	E min/max (with roll-bar)	E min/max (with cab)	F min/max	G min/max
1314	1480	735	3529	2215 / 2300	2145 / 2230	1150 / 1764	214 / 299

Dimensions in mm

	7.00-18	280/70 R18	280/70 R18 Garden	280/70 R20 *	250/80-18	280/70 R18	280/70 R18 Garden	320/65 R18	340/65 R18 *
	with fixed rim	with fixed rim	with fixed rim	with fixed rim	with adjustable rim	with adjustable rim	with adjustable rim	with adjustable rim	with adjustable rim
H	178	265	265	270	240	265	265	319	343
I	972	1005	1005	1026	996 / 1312	1074 / 1324	1074 / 1324	1074 / 1324	1082 / 1324
F	1150	1270	1270	1296	1236 / 1552	1339 / 1589	1339 / 1589	1393 / 1643	1425 / 1667

	260/70 R20	31x15.50-15 XTC	31x15.50-15 STG	33x15.50-15 XTC	280/70 R20 *	280/70 R20 * PneuTrac	250/85 R20 * (9.50-20)	300/70 R20 *	300/70 R20 * Garden
	with adjustable rim	with fixed rim	with fixed rim	with fixed rim	with adjustable rim	with adjustable rim	with adjustable rim	with adjustable rim	with adjustable rim
H	258	368	394	391	282	286	250	286	286
I	1051 / 1325	1208	1208	1208	1100 / 1448	1030 / 1410	1100 / 1448	1098 / 1478	1098 / 1478
F	1309 / 1583	1576	1602	1599	1382 / 1730	1316 / 1696	1244 / 1698	1384 / 1764	1384 / 1764

Dimensions in mm - min / max

H = Tyre width - I = Wheel track - F = Tractor width

\* Oversized planetary reduction units

TECHNICAL FEATURES	SPIRIT 70 DUALSTEER®
<b>ENGINE</b>	Kohler KDI 2504 TCR   Diesel common rail direct injection   Turbo intercooler   4 in-line cylinders 16 valves   2482 cc   Liquid cooling   Stage V
Power	46 kW / 63 hp @2600 rpm   Max torque 205 Nm@1500 rpm
Engine speed management	Electronically regulated with hand throttle knob and button with functions for: memorize/recall/exclude the set engine speed
<b>CHASSIS</b>	Swinging integral chassis (±15°) OS-FRAME with central articulation and steering wheels
<b>DRIVE</b>	Permanent four-wheel drive
<b>TRANSMISSION</b>	24-speed synchronised gearbox: 12 FWD and 12 REV with synchronised reverser
Min/max travel speed (km/h)	0.7 / 35
Transmission clutch	Multidisc in oil bath with electronically-managed and proportional hydraulic control. Power Clutch System button for engaging gears and reverser without using the clutch pedal. PRO-ACT System clutch pedal with Easy Plus™ assisted engagement. Smart Brake & Go function for automatic clutch management only with the brake pedal.
<b>DIFFERENTIAL</b>	Front and rear with simultaneous locking and electro-hydraulic control
<b>AXLES</b>	Front and rear with planetary reduction units - Optional: oversized planetary reduction units
<b>REAR PTO</b>	Independent from the gearbox and synchronised with forwarding speed. Negative safety hydraulic brake to stop the PTO
PTO clutch	Multidisc in oil bath with electro-hydraulic control
PTO rotation speed (rpm)	540/540E
<b>HYDRAULIC SYSTEM</b>	Dual circuit with independent pumps and heat exchanger
Hydraulic pump flow rate of the power steering and electro-hydraulic controls (l/min)	13
Hydraulic pump flow rate of the lift and control valves (l/min)	37 (optional circuit with increased flow rate 48 l/min)
Maximum hydraulic pressure (bar)	180
<b>REAR CONTROL VALVES</b>	Mechanically controlled
Standard	1 double-acting with float and free flow oil return (total 3 hydraulic outlets)
Optional and in addition to the standard ones	With rear up/down lift: up to 11 hydraulic outlets in total - With draft-controlled rear lift: up to 7 hydraulic outlets in total
Joystick (optional)	Proportional electronic control of rear lift and control valves consisting of: 1 continuous flow with adjustable flow rate and free flow oil return, 4 double-acting (replacing the standard ones) and circuit with increased flow rate 48 l/min (total 10 hydraulic outlets). Potentiometer for adjusting joystick sensibility. Remote control for PTO engagement. Storage armrest
<b>REAR LIFT</b>	By two external cylinders. Standard: up/down lift - Optional: position and draft-controlled
Three-point implement hitch	Standard: normal couplings cat. 1 - Optional: quick-couplings cat. 1 (arms not adjustable in length) or quick-couplings cat. 1 and 2, L-shaped, arms adjustable in length and hooks adjustable in width
Third point tie rod	Standard: with manual adjustment - Optional: hydraulically controlled upper link and tie rod link arm (only for lift with L-shaped arms cat. 1 and 2)
Ball joint lifting capacity (kg)	1900
<b>DRIVING POSITION</b>	Reversible with rotating platform suspended on silent blocks. Suspended pedals mounted on the rotating control tower
Steering wheel	Height adjustable
Seat	With gas spring for easy tipping, safety belt and man-on-board sensor. Standard: comfort seat with adjustable spring tension according to the operator's weight - Optional: 'Grammer' or 'Cobo' pneumatic seat
<b>SERVICE BRAKES</b>	Oil bath discs with hydrostatic control, acting on the rear wheels. Independent manoeuvring brakes acting on the rear wheels
Parking brake	With handle acting on service brakes
<b>STEERING</b>	Dualsteer® 4-cylinder steering system. Hydrostatic steering acting on front wheels and central joint. Flow deviator for steering unit
<b>SAFETY</b>	Front homologated roll-bar with gas spring for easy lowering and lifting
<b>CABIN (optional)</b>	Soundproofed, ROPS and FOPS homologated. Monocoque body with a 4-upright conical structure suspended on silent block. LED beacon lamp, fabric seat, USB car radio with speaker phone and sound diffusers, 2 USB outlets. Available with ventilation and heating system (VISTA model) or with air-conditioning, pressurised and category 4 certified (VISTA PRO model). FULL LED working lights on four sides, optional on VISTA and standard on VISTA PRO. Optional: active carbon filters for category 4
<b>DASHBOARD</b>	Instrument panel with analogue gauges and TFT digital colour display. Warning lights and horn
<b>ELECTRIC SYSTEM</b>	Battery 80 Ah / 12 V - Alternator 95 A
Standard equipment	Vehicle Control Unit, FULL LED street light and indicator system, front LED working lights, rear 7-pin for trailer and 3-pin sockets
<b>TYRES</b>	7.00-18 * 250/80-18 * 280/70R18 * 280/70R18 Garden * 320/65R18 * 340/65R18 * 260/70R20 * 31x15.50-15 XTC or STG * 33x15.50-15 XTC * 300/70R20 * 300/70R20 Garden * 250/85R20 * 280/70R20 * 280/70R20 PneuTrac
<b>TOW HOOKS</b>	Standard: front and rear CUNA cat. C adjustable in height - Optional: rear tow hook EC approved or EC with Slider frame or CUNA with Slider frame or EC tow bar with Slider frame
<b>RUNNING ORDER WEIGHT</b>	With roll-bar: 1830 kg - With cabin: 1960 kg
<b>ADDITIONAL OPTIONS</b>	Front bumper, beacon lamp, rear adjustable working light, Self Cleaning System™, front weights 110 kg, wheel weights 45 kg each (for 18" wheels) and 50 kg each (for 20" wheels), Dual Floating System™ hydraulic suspension. Silver and bordeaux 'Special Edition' livery

# SPIRIT 70 MT

## Data Sheet

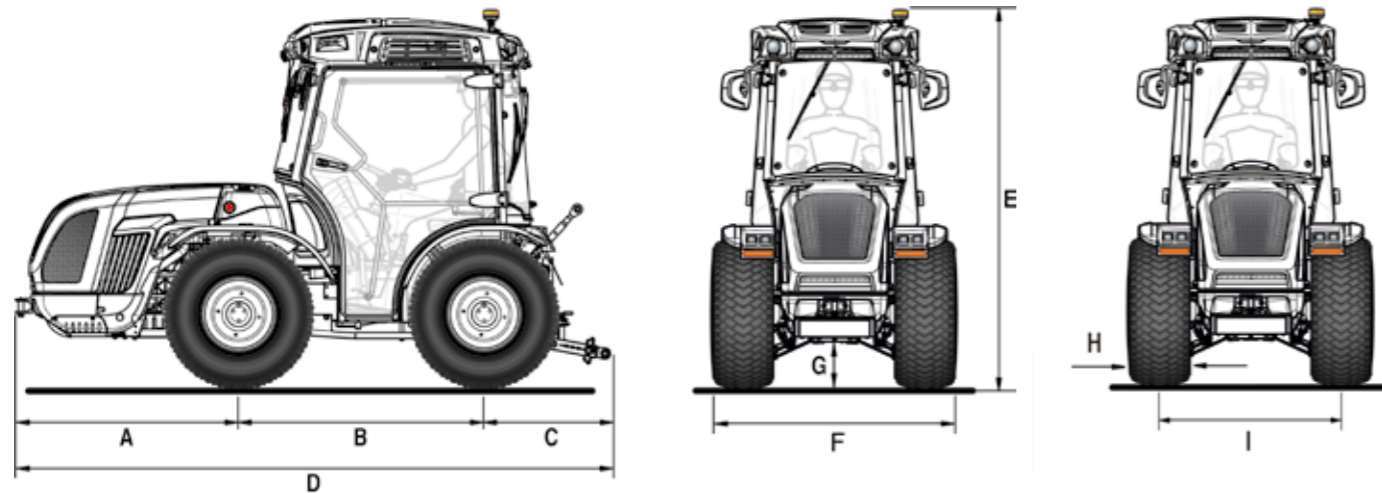

A	B	C	D	E min/max	F min/max	G min/max
1314	1480	735	3529	2145 / 2195	1684 / 1710	207 / 266

Dimensions in mm

	31x15.50-15 XTC	31x15.50-15 STG	33x15.50-15 XTC
	with fixed rim	with fixed rim	with fixed rim
H	368	394	391
I	1316	1316	1316
F	1684	1710	1707

Dimensions in mm  
H = Tyre width - I = Wheel track - F = Tractor width

TECHNICAL FEATURES	SPIRIT 70 MT
<b>ENGINE</b>	Kohler KDI 2504 TCR   Diesel common rail direct injection   Turbo intercooler   4 in-line cylinders 16 valves   2482 cc   Liquid cooling   Stage V
Power	46 kW / 63 hp @2600 rpm   Max torque 205 Nm@1500 rpm
Engine speed management	Electronically regulated with hand throttle knob and button with functions for: memorize/recall/exclude the set engine speed
<b>Self Cleaning System™</b>	Automatic radiator and engine intake grille cleaning system to prevent overheating
<b>CHASSIS</b>	Swinging integral chassis (±15°) OS-FRAME with steering wheels
<b>DRIVE</b>	Permanent four-wheel drive
<b>TRANSMISSION</b>	24-speed synchronised gearbox: 12 FWD and 12 REV with synchronised reverser
Min/max travel speed (km/h)	0.7 / 35
<b>Transmission clutch</b>	Multidisc in oil bath with electronically-managed and proportional hydraulic control. Power Clutch System button for engaging gears and reverser without using the clutch pedal. PRO-ACT System clutch pedal with Easy Plus™ assisted engagement. Smart Brake & Go function for automatic clutch management only with the brake pedal.
<b>DIFFERENTIAL</b>	Front and rear with simultaneous locking and electro-hydraulic control
<b>AXLES</b>	Front and rear with planetary reduction units
REAR PTO	Independent from the gearbox and synchronised with forwarding speed. Negative safety hydraulic brake to stop the PTO
PTO clutch	Multidisc in oil bath with electro-hydraulic control
<b>PTO rotation speed (rpm)</b>	540/540E
<b>HYDRAULIC SYSTEM</b>	Dual circuit with independent pumps and heat exchanger
Hydraulic pump flow rate of the power steering and electro-hydraulic controls (l/min)	13
Hydraulic pump flow rate of the lift and control valves (l/min)	37 (optional circuit with increased flow rate 48 l/min)
<b>Maximum hydraulic pressure (bar)</b>	180
<b>REAR CONTROL VALVES</b>	Mechanically controlled
Standard	1 double-acting with float and free flow oil return (total 3 hydraulic outlets)
Optional and in addition to the standard ones	Up to 7 hydraulic outlets in total
<b>REAR LIFT</b>	Four external cylinders with Dual Floating System® hydraulic suspension
Three-point implement hitch	Standard: quick-couplings cat. 1 and 2, L-shaped, arms adjustable in length and hooks adjustable in width - Optional: quick-couplings cat. 1 (arms not adjustable in length)
Third point tie rod	Standard: with manual adjustment - Optional: hydraulically controlled upper link and tie rod link arm (only for lift with L-shaped arms cat. 1 and 2)
Ball joint lifting capacity (kg)	1900
<b>DRIVING POSITION</b>	Reversible with rotating platform suspended on silent blocks. Suspended pedals mounted on the rotating control tower
Steering wheel	Height adjustable
Seat	With gas spring for easy tipping, safety belt and man-on-board sensor. Standard: comfort seat with adjustable spring tension according to the operator's weight - Optional: 'Grammer' or 'Cobo' pneumatic seat
<b>SERVICE BRAKES</b>	Oil bath discs with hydrostatic control, acting on the rear wheels. Independent manoeuvring brakes acting on the rear wheels
Parking brake	With handle acting on service brakes
<b>STEERING</b>	Hydrostatic steering acting on the front wheels. Flow deviator for steering unit
<b>SAFETY</b>	Standard: VISTA cab, soundproofed, ROPS and FOPS homologated. Monocoque body with a 4-upright conical structure suspended on silent block. Ventilation and heating system, LED beacon lamp, fabric seat, USB car radio with speaker phone and sound diffusers, 2 USB outlets. Optional: FULL LED working lights on four sides
<b>CABIN (optional)</b>	VISTA PRO cab, soundproofed, ROPS and FOPS homologated, pressurised and category 4 certified. Monocoque body with a 4-upright conical structure suspended on silent block. Air-conditioning, LED beacon lamp, fabric seat, USB car radio with speaker phone and sound diffusers, 2 USB outlets. FULL LED working lights on four sides. Optional: active carbon filters for category 4
<b>DASHBOARD</b>	Instrument panel with analogue gauges and TFT digital colour display. Warning lights and horn
<b>ELECTRIC SYSTEM</b>	Battery 80 Ah / 12 V - Alternator 95 A
Standard equipment	Vehicle Control Unit, FULL LED street light and indicator system, front LED working lights, rear 7-pin for trailer and 3-pin sockets
<b>TYRES</b>	31x15.50-15 XTC or STG * 33x15.50-15 XTC
<b>TOW HOOKS</b>	Standard: front and rear CUNA cat. C adjustable in height - Optional: rear tow hook EC approved or EC with Slider frame or CUNA with Slider frame or EC tow bar with Slider frame
<b>RUNNING ORDER WEIGHT</b>	With cabin: 1960 kg
<b>ADDITIONAL OPTIONS</b>	Front bumper, front weights 110 kg. Silver and bordeaux 'Special Edition' livery

## THE SERVICES

---



### SPARE PARTS

A complete range of original spare parts, guaranteed directly by the manufacturer.



### ASSISTANCE

A team of specialists, well prepared and available to assure an efficient and resolving service.



### LUBRICANTS

We recommend to use the original PowerLube lubricants.



### FINANCIAL SERVICES

Financial solutions to meet the credit requirements.



M A D E I N I T A L Y

